



# ***ALLOY CUSTOM PRODUCTS INC.***

*MODEL: ACP T-50 LAR (ALUMINUM)*





# ALLOY CUSTOM PRODUCTS INC.

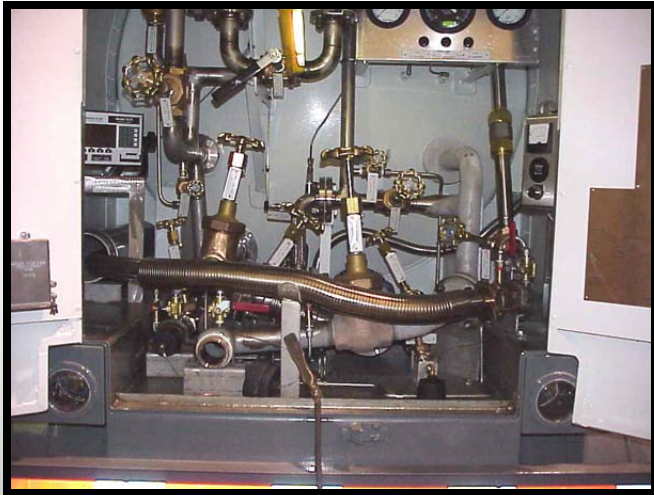

## MODEL: ACP T-50

MAXIMIZED FOR LAR SERVICE

PRODUCT: LAR

WARM WATER CAPACITY: 4,699 US GALLONS

LAR @ 55% : 4,412 US GALLONS

MAWP: 48 PSIG

BAFFLES: 3 TRASVERSE BAFFLES

MANWAY: WELDED (NON-ENTRY)

OUTER VESSEL: 5083 ALUMINUM

INNER VESSEL: 5083 ALUMINUM

SUSPENSION: AIR RIDE

PUMP DRIVE: CUSTOMER SPECIFIED

PIPING FEATURES:

BRONZE VAVLES

EASY PRIME PUMP LOCATION

EASY FLOW PIPING ARRANGEMENT

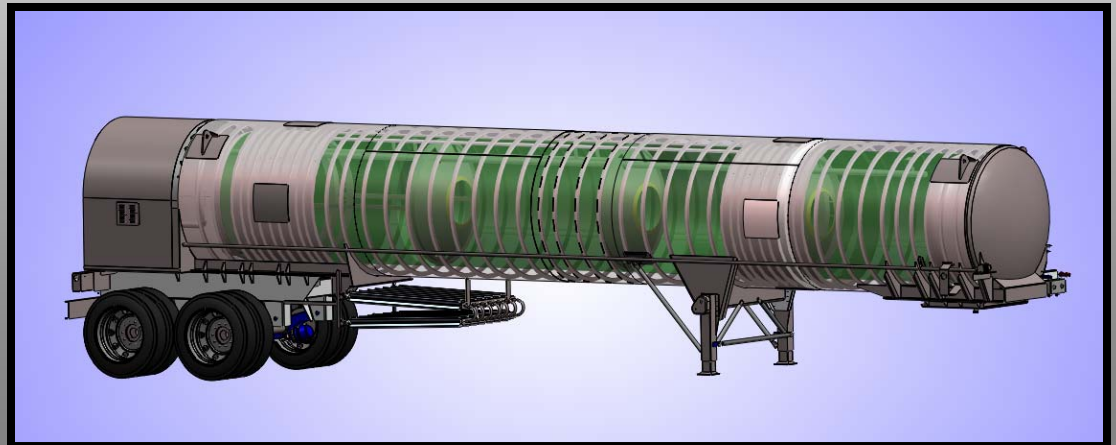
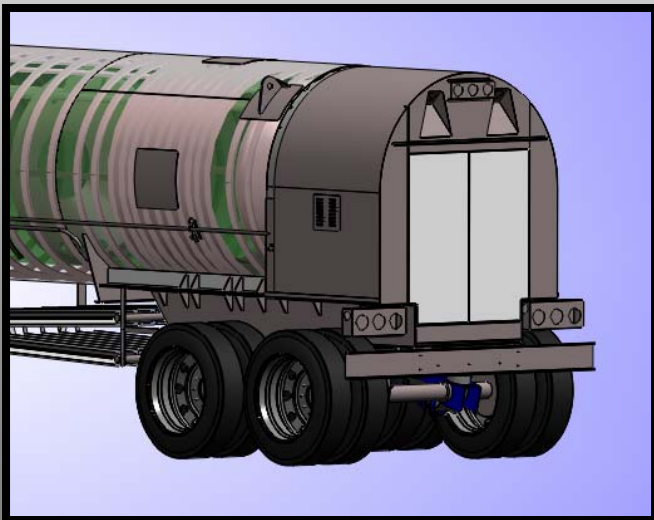



# ALLOY CUSTOM PRODUCTS INC.

## MODEL: ACP T-50

MAXIMIZED FOR LAR SERVICE

PRODUCT: LAR

WARM WATER CAPACITY: 4,699 US GALLONS

LAR @ 55% : 4,412 US GALLONS

MAWP: 48 PSIG

BAFFLES: 3 TRANSVERSE BAFFLES

MANWAY: WELDED (NON-ENTRY)

OUTER VESSEL: 5083 ALUMINUM

INNER VESSEL: 5083 ALUMINUM

SUSPENSION: AIR RIDE

PUMP DRIVE: CUSTOMER SPECIFIED

PIPING FEATURES:

BRONZE VAVLES

EASY PRIME PUMP LOCATION

EASY FLOW PIPING ARRANGEMENT

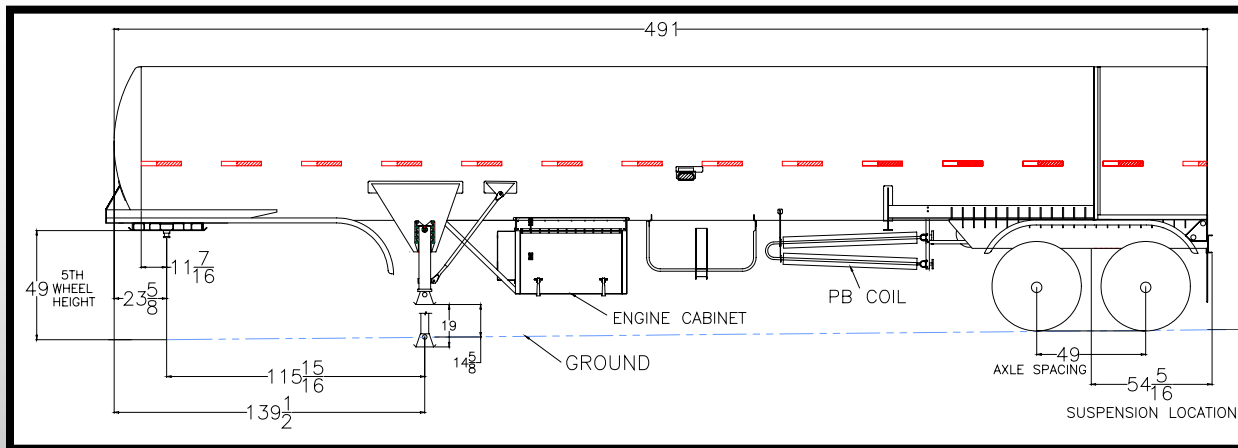

	STEERING AXLE		KINGPIN		TRACTOR TANDEM		TRAILER TANDEM		TOTAL WEIGHT	
	POUNDS	KG	POUNDS	KG	POUNDS	KG	POUNDS	KG	POUNDS	KG
TRACTOR TARE	9,340	4,237	0	0	8,120	3,683	0	0	17,460	7,920
TRAILER TARE	404	183	4,332	1,965	3,928	1,782	9,509	4,313	13,841	6,278
PAYLOAD	2,253	1,022	24,175	10,966	21,922	9,944	24,424	11,079	48,599	22,045
FULL COMBINATION	11,997	5,442	28,507	12,931	33,970	15,409	33,933	15,392	79,900	36,243



# ALLOY CUSTOM PRODUCTS INC.

## MODEL: ACP T-50 FLOW SCHEMATIC

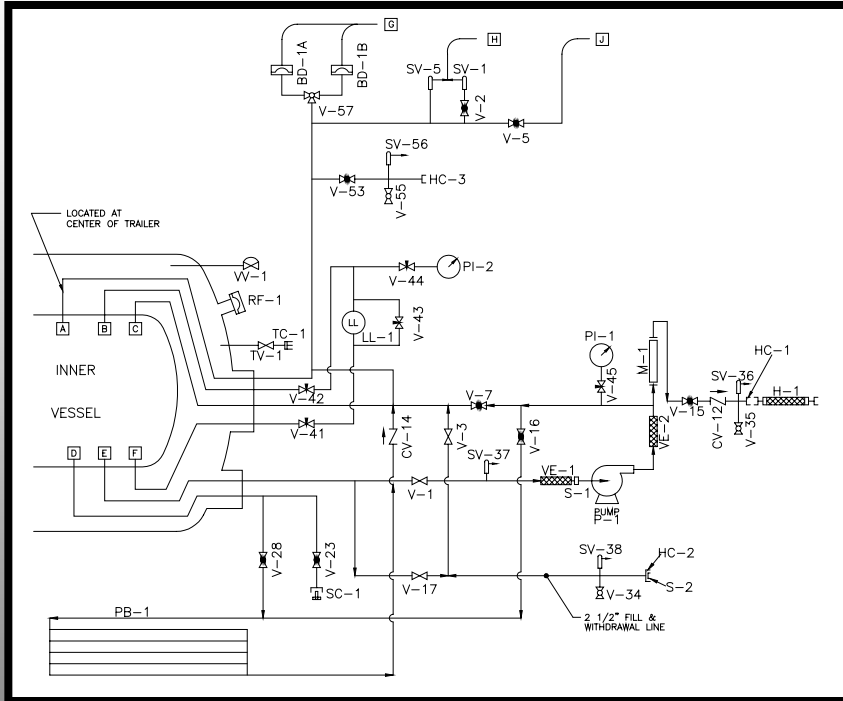

ITEM	DESCRIPTION	SIZE	MANUFACTURER
V-1	PUMP INLET VALVE, GATE	2 1/2"	GOO DARD #B310120 T
V-2	OVER THE ROAD ISOLATION VALVE, GLOBE	1 1/2"	GOO DARD #B2221-1 T
V-3	TOP FILL VALVE, GATE	2 1/2"	GOO DARD #B310120 T
V-5	VENT VALVE, GLOBE	2"	GOO DARD #B222-16 T
V-1	REGULATION VALVE, GLOBE	1 1/2"	GOO DARD #B2221812 T
V-15	PUMP DISCHARGE VALVE, GLOBE	1 1/2"	GOO DARD #B2221812 T
V-16	FORCE FEED VALVE, GLOBE	1 1/2"	GOO DARD #B2221-1 T
V-11	FILL VALVE, GATE	2 1/2"	GOO DARD #B3101-20 T
V-23	LKUB SAMPLE VALVE, GLOBE	1 1/2"	GOO DARD #B2221-1 T
V-22	PRESSURE BUILD FEED VALVE, GLOBE	1 1/2"	GOO DARD #B2221812 T
V-31	FILL HOSE BLEED VALVE, BALL	1 1/2"	WORCESTER #X111 TSE
V-35	PUMP DISCHARGE BLEED VALVE, BALL	1 1/2"	WORCESTER #X111 TSE
V-11	HIGH PRESSURE ISOLATION VALVE, NEEDLE	1/8"	HOKE D31 12-402-B-HP-S-12
V-12	LOW PRESSURE ISOLATION VALVE, NEEDLE	1/8"	HOKE D31 12-402-B-HP-S-12
V-13	L.L. GAGE EQUAL VALVE, NEEDLE	1/8"	HOKE D31 12-402-B-HP-S-12
V-11	PRESSURE GAGE ISOLATION VALVE, NEEDLE	1/8"	HOKE D31 12-402-B-HP-S-12
V-15	PUMP PRESSURE GAGE ISOLATION VALVE, NEEDLE	1/8"	HOKE D31 12-402-B-HP-S-12
V-53	VAPOR RECOVERY VALVE, GLOBE	1 1/2"	GOO DARD #B2221812 T
V-55	VAPOR RECOVERY BLEED VALVE, BALL	1 1/2"	WORCESTER #X111 TSE
V-51	BURSTS TO DISCHARGE VALVE, BALL	2"	TRIFLEX #15120836 C T
CV-12	PUMP DISCHARGE SWING CHECK	1 1/2"	GOO DARD #S2241-128W-510
CV-11	PRESSURE BUILD COIL GAS PHASE SWING CHECK	2"	GOO DARD #S2241-160W-510
VA-1	MAIN VACUUM VALVE, DIAPHRAGM	1 1/2"	HILLS MACANNA #5062-N1
TV-1	THERMOCUPLE ISOLATION VALVE, BELLOWS SEAL	1/8"	HOKE #1551-F28-HP-S-12
TC-1	THERMOCUPLE	-	FREDRICKS #2108-10-2A
RF-1	OUTER VESSEL SAFETY HEAD, O-RING, SEE NOTE 6	6"	-
SV-1	RO-RO RELIEF REGULATOR VALVE, SET @ 11 PSIG	1 1/2"	MC CASH #FRM2
SV-5	MAIN TANK SAFETY, SET @ 10 PSIG, SEE NOTE 5	1 1/2" x 2"	ROCKWOOD SWIND EMAN #RX350
SV-28	PUMP DISCHARGE SAFETY, SET @ 150 PSIG	1 1/2"	GENERANT CRVP1 5000-PS-150 PSI
SV-31	PUMP SUCTION SAFETY, SET @ 30 PSIG	1 1/2"	GENERANT CRVP1 5000-PS-30 PSI
SV-32	FILL LINE SAFETY, SET @ 100 PSIG	1 1/2"	GENERANT CRVP1 5000-PS-100 PSI
SV-36	VAPOR RECOVERY LINE SAFETY, SET @ 100 PSIG	1 1/2"	GENERANT CRVP1 5000-PS-100 PSI
BB-1A	RUP TURE DISC, SET @ 55 PSIG, SEE NOTE 1	2"	FKE QUICK SETS55 WINKLE DISC
BB-1B	RUP TURE DISC, SET @ 55 PSIG, SEE NOTE 1	2"	FKE QUICK SETS55 WINKLE DISC
VE-1	VIBRATION ELIMINATOR	2 1/2"	FLEXIBLE COMPONENTS
VE-2	VIBRATION ELIMINATOR	1 1/2"	FLEXIBLE COMPONENTS
S-1	PUMP INLET STRAINER	2 1/2"	10 MESH, MONEL
S-2	FILL LINE SCREEN	2 1/2"	10 MESH, MONEL
H-1	HOSE, 16 FT LONG W/ WELDED CONNECTIONS	2"	FLEXIBLE COMPONENTS #32MS2105000 514355 HP ARHEA
HC-1	PUMP DISCHARGE HOSE CONNECTION, SS	1 1/2"	ACME #AR-150-550-106-15
HC-2	FILL HOSE CONNECTION, SS	2 1/2"	ACME #AR-250-550-106-25
HC-3	VAPOR RECOVERY HOSE CONNECTION, SS	1 1/2"	ACME #AR-150-550-106-15
SC-1	SAMPLE CONNECTION, ARGON	-	SWAGelok #55-0C 1481-100-K3 2 PLUG #55-0C 148-K3
M-1	METER	2"	SPONSER #450 DN
PI-1	VESSEL PRESSURE GAGE, 0-100 PSIG	1 1/2" DIAL	WEKSLER
PI-2	PUMP DISCHARGE PRESSURE GAGE, 0-100 PSIG	1 1/2" DIAL	WEKSLER
LL-1	LKUB LEVEL GAGE, 0-50 IN	6" DIAL	BARTON #221
P-1	PUMP, CENTRIFUGAL	6"	AED LECTRAN
PB-1	PRESSURE BUILDING COIL	-	-

Contact Information:

P.o.Box 198

Delphi, IN 46923

800-359-2556

sales@alloycustomproducts.com