



ALLOY CUSTOM PRODUCTS INC.

MODEL: ACP ST-77 LIN





ALLOY CUSTOM PRODUCTS INC.



MODEL: ACP ST-77

MAXIMIZED FOR CANADIAN LIN SERVICE

PRODUCT: LIN

WARM WATER CAPACITY: 7,706 US GALLONS

LIN @ 95% : 7,259 US GALLONS

MAWP: 38 PSIG

BAFFLES: 3 TRANSVERSE BAFFLES

MANWAY: WELDED (ENTRY)

OUTER VESSEL: A607-50 CARBON STEEL

INNER VESSEL: SA240-304 STAINLESS STEEL

SUSPENSION: AIR RIDE

PUMP DRIVE: ENGINE DRIVEN

PIPING FEATURES:

STAINLESS STEEL AND BRONZE VALVES

EASY PRIME PUMP LOCATION

EASY FLOW PIPING ARRANGEMENT





ALLOY CUSTOM PRODUCTS INC.

MODEL: ACP ST-77

MAXIMIZED FOR CANADIAN LIN SERVICE

PRODUCT: LIN

WARM WATER CAPACITY: 7,706 US GALLONS

LIN @ 95% : 7,259 US GALLONS

MAWP: 38 PSIG

BAFFLES: 3 TRANSVERSE BAFFLES

MANWAY: WELDED (ENTRY)

OUTER VESSEL: A607-50 CARBON STEEL

INNER VESSEL: SA240-304 STAINLESS STEEL

SUSPENSION: AIR RIDE

PUMP DRIVE: ENGINE DRIVEN

PIPING FEATURES:

STAINLESS STEEL AND BRONZE VALVES

EASY PRIME PUMP LOCATION

EASY FLOW PIPING ARRANGEMENT

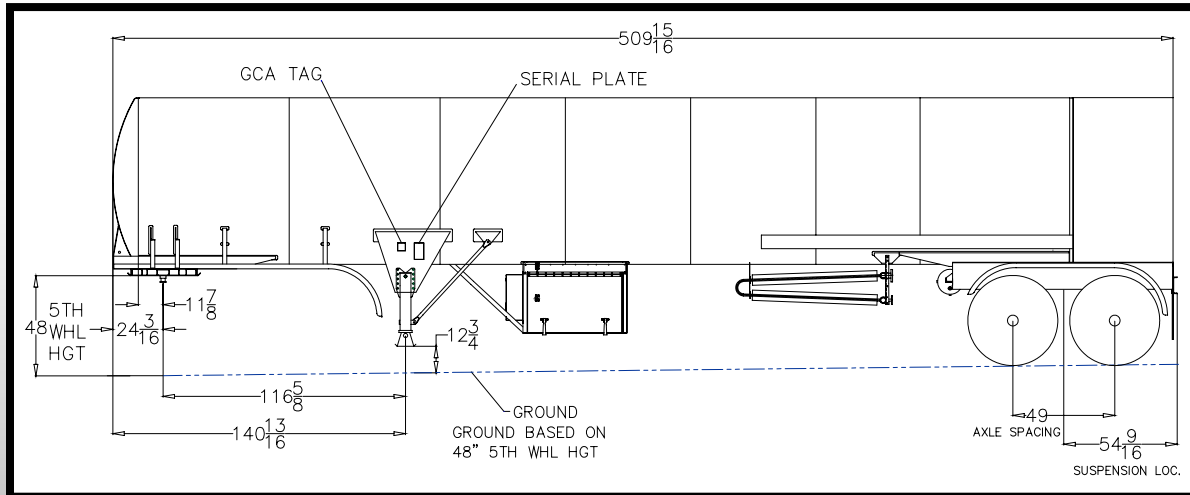

	STEERING AXLE		KINGPIN		TRACTOR TANDEM		TRAILER TANDEM		TOTAL WEIGHT	
	POUNDS	KG	POUNDS	KG	POUNDS	KG	POUNDS	KG	POUNDS	KG
TRACTOR TARE	9,535	4,324.98	0	0	7,012	3,180.57	0	0	16,547	7,505.55
TRAILER TARE	562	254.91	6,711	3,044.04	6,149	2,789.12	11,714	5,313.35	18,425	8,357.39
PAYLOAD	1,903	863.18	22,742	10,315.54	20,838	9,451.90	22,286	10,108.70	45,028	20,424.25
FULL COMBINATION	12,000	5,443.08	29,453	13,359.58	34,000	15,422.06	34,000	15,422.06	80,000	36,287.20

