



ALLOY CUSTOM PRODUCTS INC.

MODEL: ACP ST-76 LOX, LIN, LAR





ALLOY CUSTOM PRODUCTS INC.



MODEL: ACP ST-76

OPTIMIZED FOR MULTI-PRODUCT SERVICE APPLICATIONS

SPECIFICATIONS:

PRODUCT: LOX, LIN, LAR

WARM WATER CAPACITY: 7,706 US GALLONS

LOX @ 67% : 5,119 US GALLONS

LIN @ 95% : 9,722.2 US GALLONS

LAR @ 55% : 4,203 US GALLONS

MAWP: 38 PSIG

BAFFLES: 3 TRASVERSE BAFFLES

MANWAY: WELDED (NON-ENTRY)

OUTER VESSEL: A607-50 CARBON STEEL

INNER VESSEL: SA240-304 STAINLESS STEEL

SUSPENSION: AIR RIDE

PUMP DRIVE: ENGINE DRIVEN

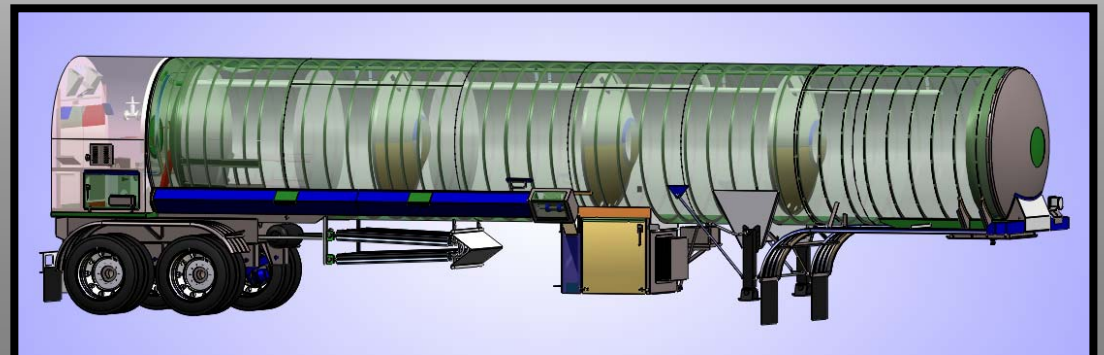



ALLOY CUSTOM PRODUCTS INC.

MODEL: ACP ST-76

OPTIMIZED FOR MULTI-PRODUCT SERVICE APPLICATIONS

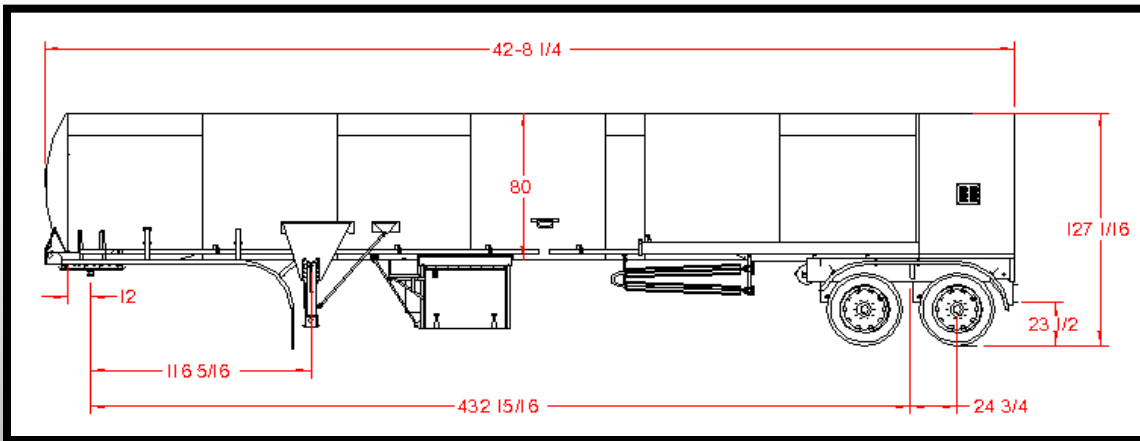

SPECIFICATIONS:

PRODUCT: LOX, LIN, LAR

WARM WATER CAPACITY: 7,706 US GALLONS

LOX @ 67% : 5,119 US GALLONS

LIN @ 95% : 9,722.2 US GALLONS

LAR @ 55% : 4,203 US GALLONS

MAWP: 38 PSIG

BAFFLES: 3 TRASVERSE BAFFLES

MANWAY: WELDED (NON-ENTRY)

OUTER VESSEL: A607-50 CARBON STEEL

INNER VESSEL: SA240-304 STAINLESS STEEL

SUSPENSION: AIR RIDE

PUMP DRIVE: ENGINE DRIVEN

	STEERING AXLE		KINGPIN		TRACTOR TANDEM		TRAILER TANDEM		TOTAL WEIGHT	
	POUNDS	KG	POUNDS	KG	POUNDS	KG	POUNDS	KG	POUNDS	KG
TRACTOR TARE	9,535	4,324.98	0	0	7,012	3,180.57	0	0	16,547	7,505.55
TRAILER TARE	562	254.78	6,711	3,044.04	6,149	2,789.12	11,714	5,313.35	18,425	8,357.39
PAYLOAD	1,903	863.18	22,742	9,913.23	20,838	9,451.90	22,286	10,108.70	45,028	20,424.25
FULL COMBINATION	12,000	5,443.08	29,453	12,359.58	34,000	15,422.06	34,000	15,422.06	80,000	36,287.20

