



ALLOY CUSTOM PRODUCTS INC.

MODEL: ACP ST-72 LOX, LIN, LAR





ALLOY CUSTOM PRODUCTS INC.

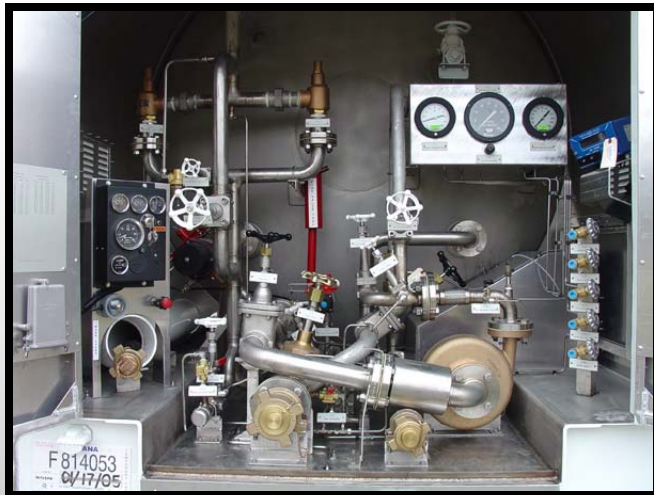

MODEL: ACP ST-72

OPTIMIZED FOR MULTI-PRODUCT SERVICE APPLICATIONS

SPECIFICATIONS:

PRODUCT: LOX, LIN, LAR

WARM WATER CAPACITY: 7,214 US GALLONS

LOX @ 67% : 4,793 US GALLONS

LIN @ 95% : 6,796 US GALLONS

LAR @ 55% : 3,935 US GALLONS

MAWP: 38 PSIG

BAFFLES: 3 TRASVERSE BAFFLES

MANWAY: WELDED (NON-ENTRY)

OUTER VESSEL: A607-50 CARBON STEEL

INNER VESSEL: SA240-304 STAINLESS STEEL

SUSPENSION: AIR RIDE

PUMP DRIVE: ENGINE DRIVEN

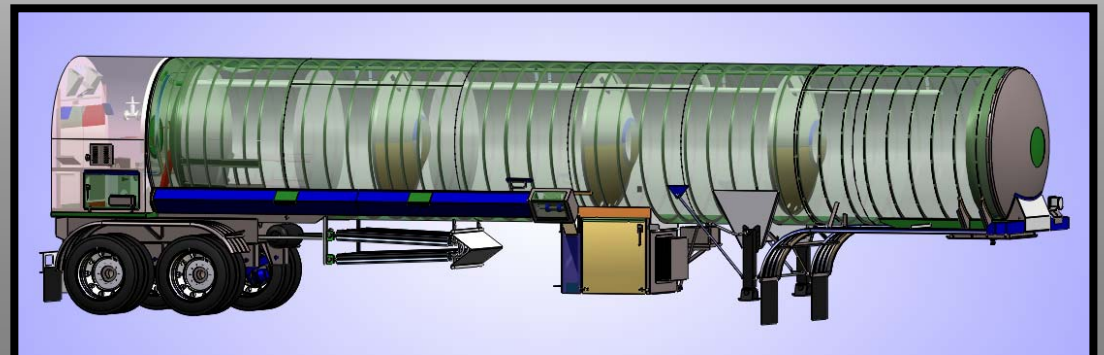



ALLOY CUSTOM PRODUCTS INC.

MODEL: ACP ST-72

OPTIMIZED FOR MULTI-PRODUCT SERVICE APPLICATIONS

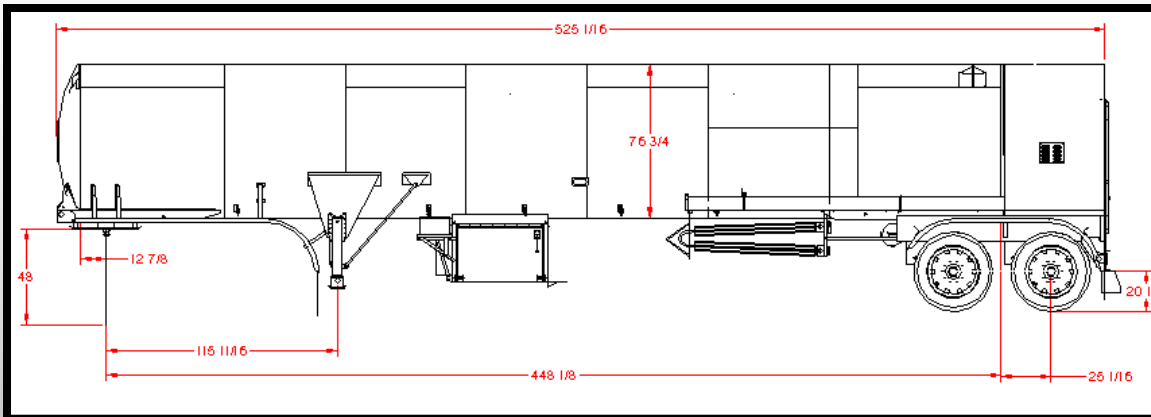

SPECIFICATIONS:

PRODUCT: LOX, LIN, LAR

WARM WATER CAPACITY: 7,214 US GALLONS

LOX @ 67% : 4,793 US GALLONS

LIN @ 95% : 6,796 US GALLONS

LAR @ 55% : 3,935 US GALLONS

MAWP: 38 PSIG

BAFFLES: 3 TRANSVERSE BAFFLES

MANWAY: WELDED (NON-ENTRY)

OUTER VESSEL: A607-50 CARBON STEEL

INNER VESSEL: SA240-304 STAINLESS STEEL

SUSPENSION: AIR RIDE

PUMP DRIVE: ENGINE DRIVEN

WEI GHT DI STRI BUTI ON:	FRONT	REAR	REAR		
	TRACTOR	TRACTOR	TRAI LER	TOTAL	KI NGPI N
TRACTOR TARE	8662	7157	0	15819	
TRAI LER TARE	753	6058	11518	18329	6811
PAYLOAD	2585	20784	22483	45852	23369
TOTAL	12000	33999	34001	80000	30180



ALLOY CUSTOM PRODUCTS INC.

MODEL: ACP ST-72 FLOW SCHEMATIC

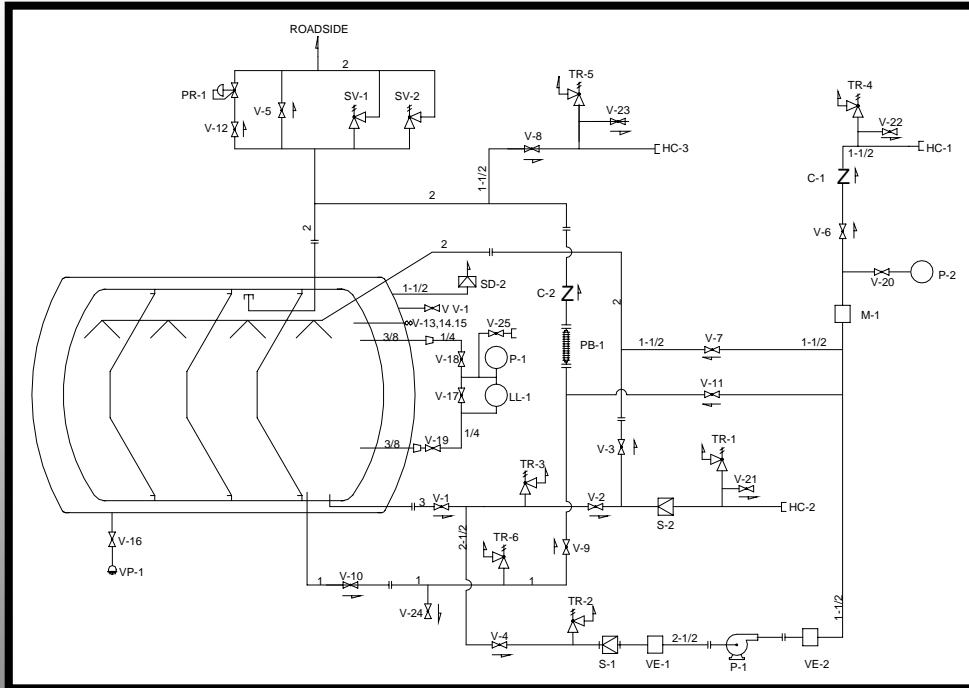

ITEM	DESCRIPTION	SIZE
C-1	PUMP-DISCHARGE CHECK VALVE	1-1/2
C-2	PB COIL VAPOR-RETURN CHECK VALVE	2
DC-1	DISCHARGE HOSE	1-1/2
DC-2	FILL-DRAIN LINE CONNECTION	3
LL-1	LIQUID LEVEL GAUGE	-
M-1	FLOW METER	-
P-1	PUMP	-
PB-1	PRESSURE-BUILD COIL	-
PR-1	OTR. REGULATOR	1/2
P-1	INNER-VESSEL PRESSURE GAUGE	-
P-2	PUMP-DISCHARGE PRESSURE GAUGE	-
S-1	PUMP INLET STRAINER	2-1/2
S-2	FILL-LINE STRAINER	2
SD-2	OUTER-JACKET PRESSURE RELIEF PLATE	5
SV-1	INNER-VESSEL SAFETY RELIEF VALVE 38 PSIG	2
SV-2	INNER-VESSEL SAFETY RELIEF VALVE 57 PSIG	2
TR-1	FILL-LINE THERMAL RELIEF VALVE 50 PSIG	1/2
TR-2	PUMP INLET-LINE THERMAL RELIEF VALVE 50 PSIG	1/2
TR-3	FCV-1 THERMAL RELIEF VALVE 200 PSIG	1/2
TR-4	PUMP DISCHARGE-LINE THERMAL RELIEF VALVE 450 PSIG	1/2
V-1	FILL-DRAIN LINE FIRE CONTROL VALVE	3
V-2	BOTTOM FILL VALVE	3
V-3	TOP FILL VALVE	2
V-4	PUMP INLET VALVE	2-1/2
V-5	MANUAL VENT VALVE	2
V-6	METER DISCHG	1-1/2
V-7	PUMP RECIRCULATION VALVE	1-1/2
V-8	PB INLET	1
V-9	PB COIL FORCE FEED	1/2
V-10	OTR. ISOLATION	1/2
V-11	LINE TRYCOCK	3/8
V-12	LOX TRYCOCK	3/8
V-13	LAR TRYCOCK	3/8
V-14	LIQUID SAMPLE VALVE	3/8
V-15	GAS SAMPLE	3/8
V-16	THERMOCOUPLE ISOLATION VALVE	1/8
V-17	LL GAUGE EQUALIZATION VALVE	1/4
V-18	L.P. ISOLATION	1/4
V-19	H.P. ISOLATION	1/4
V-20	PUMP DISCHARGE PRESSURE GAUGE ISOLATION VALVE	1/4
V-21	FILL LINE BLEED VALVE	3/8
V-22	DISCHARGE LINE BLEED VALVE	3/8
VE-1	PUMP INLET VIBRATION ISOLATOR	2-1/2
VE-2	PUMP DISCHARGE VIBRATION ISOLATOR	1-1/2
VP-1	THERMOCOUPLE PROBE	1/8
V V-1	EVACUATION	1-1/2

Contact Information:

P.o.Box 198

Delphi, IN 46923

800-359-2556

sales@alloycustomproducts.com