



# ***ALLOY CUSTOM PRODUCTS INC.***

*MODEL: ACP ST-13 LNG*





# ALLOY CUSTOM PRODUCTS INC.

## MODEL: ACP ST-13

### MAXIMIZED FOR LNG SERVICE

PRODUCT: LNG

WARM WATER CAPACITY: 12,975 US GALLONS

LNG @ MC338 LEVEL : 11,320 US GALLONS

MAWP: 70 PSIG

BAFFLES: 3 TRASVERSE BAFFLES

MANWAY: WELDED (NON-ENTRY)

OUTER VESSEL: A607-50 CARBON STEEL  
SA240-304 STAINLESS STEEL

INNER VESSEL: SA240-304 STAINLESS STEEL

SUSPENSION: AIR RIDE

DELIVERY SYSTEM: PRESSURE OFF

### PIPING FEATURES:

STAINLESS STEEL VAVLES

EASY FLOW PIPING ARRANGEMENT





# ALLOY CUSTOM PRODUCTS INC.

## MODEL: ACP ST-13

MAXIMIZED FOR LNG SERVICE

PRODUCT: LNG

WARM WATER CAPACITY: 12,975 US GALLONS

LNG @ MC338 LEVEL: 11,320 US GALLONS

MAWP: 70 PSIG

BAFFLES: 3 TRANSVERSE BAFFLES

MANWAY: WELDED (NON-ENTRY)

OUTER VESSEL: A607-50 CARBON STEEL

SA240-304 STAINLESS STEEL

INNER VESSEL: SA240-304 STAINLESS STEEL

SUSPENSION: AIR RIDE

DELIVERY SYSTEM: PRESSURE OFF

PIPING FEATURES:

STAINLESS STEEL VALVES

EASY FLOW PIPING ARRANGEMENT

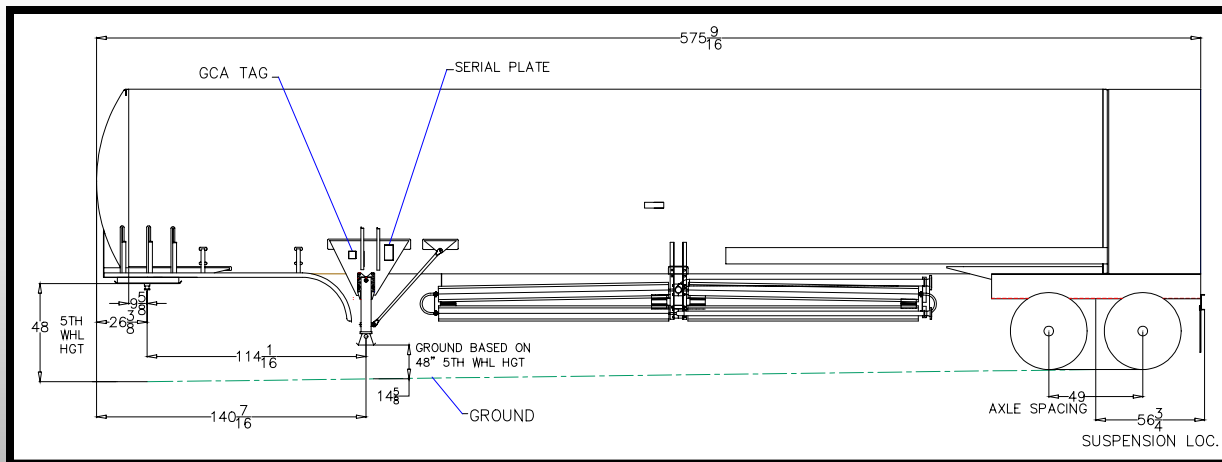

NOTE: THIS IS A SAMPLE WEIGHT DISTRIBUTION. DATA IS DEPENDANT ON TRACTOR WEIGHT.

WEIGHT DISTRIBUTION:	FRONT TRACTOR	REAR TRACTOR	REAR TRAILER	TOTAL	KINGPIN
TRACTOR TARE	9473	7515	0	16988	
TRAILER TARE	894	9366	15680	25940	10260
PAYLOAD	1630	17089	18353	37072	18719
TOTAL	11997	33970	34032	80000	28980



# ALLOY CUSTOM PRODUCTS INC.

## MODEL: ACP ST-13 FLOW SCHEMATIC

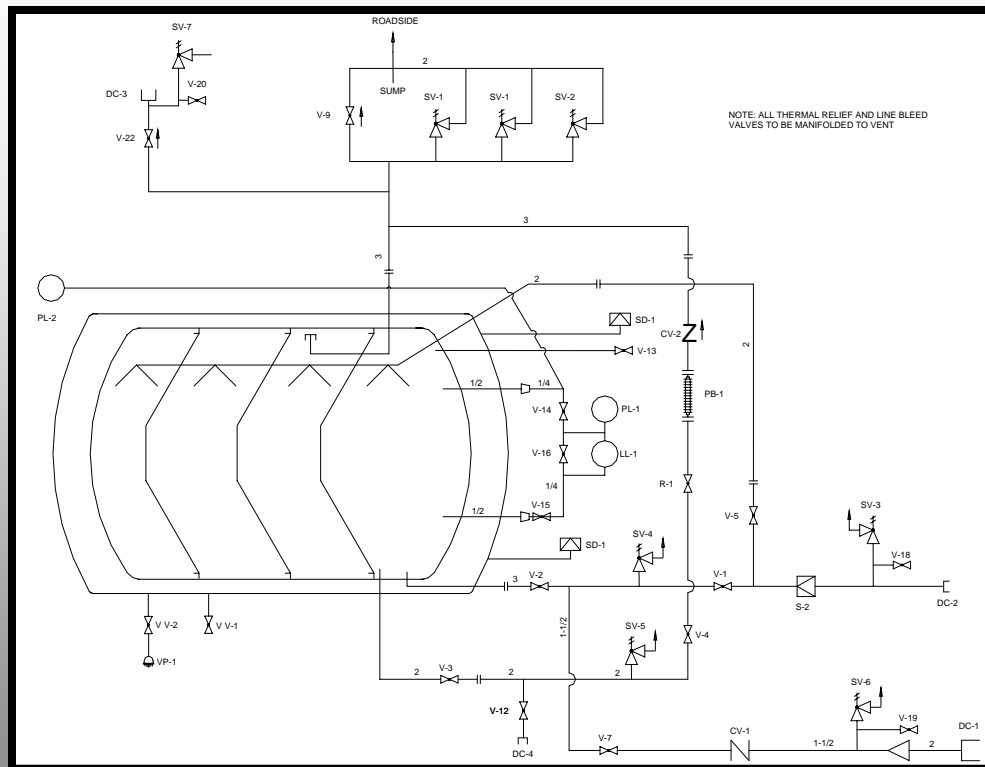

ITEM	DESCRIPTION	SIZE
V-1	FILL-DRAIN-LINE VALVE GLOBE	3
V-2	FIRE BLOCK VALVE SPRING OP BALL	3
V-3	FIRE BLOCK VALVE, PB, SPRING OP BALL	2
V-4	PRESSURE BUILD VALVE, GLOBE	2
V-5	TOP FILL VALVE, GLOBE	2
V-7	DISCHARGE LINE VALVE, GLOBE	1-1/2
V-9	MANUAL VENT VALVE, GLOBE	2
V-12	LIQUID SAMPLE VALVE, GLOBE	1/4
V-13	FULL TRYCOCK, GLOBE	1/4
V-14	AFT LP. ISOLATION VALVE, NEEDLE	1/4
V-15	AFT HP. ISOLATION VALVE, NEEDLE	1/4
V-16	LL GAGE EQUAL VALVE NEEDLE	1/4
V-18	FILL LINE BLEED VALVE, BALL	3/8
V-19	WITHDRAWAL LINE BLEED VALVE, BALL	3/8
V-20	VAPOR RECOVERY BLEED VALVE, BALL	3/8
V-22	VAPOR RECOVERY VALVE, GLOBE	2
V V-1	MAIN VACUUM VALVE DIAPHRAM	1-1/2
V V-2	TC ISOLATION VALVE BELLOWS-SEALED	1/8
VP-1	THERMOCOUPLE HASTINGS DV-6R	--
SD-1	JACKET VACUUM RELIEF, O-RING (2)	6
SV-1	INNER-VESSEL RELIEF VALVE 70 PSI	1 1/2
SV-2	SECONDARY INNER-VESSEL RELIEF VALVE 105 PSI	1 1/2
SV-3	FILL LINE RELIEF VALVE 200 PSI	1/2
SV-4	FIRE BLOCK RELIEF VALVE 200 PSI	1/2
SV-5	PB FIRE BLOCK RELIEF VALVE 200 PSI	1/2
SV-6	DISCHARGE RELIEF VALVE 200 PSI	1/2
SV-7	VAPOR RECOVERY RELIEF VALVE 200 PSI	1/2
S-2	FILL-LINE STRAINER 40 MESH	3
CV-1	DISCHARGE CHECK VALVE	1-1/2
CV-2	PB COIL OUTLET CHECK VALVE	3
PL-1	AFT INNER-VESSEL PRESSURE GAUGE 0-150 PSI	4 1/2 DIAL
PL-2	FWD INNER VESSEL PRESSURE GAUGE 0-150 PSI	4 1/2 DIAL
LL-1	LIQUID LEVEL GAUGE 0-60 W.C.	6 DIAL
PB-1	PRESSURE-BUILD COIL	-
DC-1	DISCHARGE CONN. (CGA LNG-300)	2 FPT x 3 CGA
DC-2	FILL-DRAIN-LINE CONN. (CGA LNG-300)	3 FPT x 3 CGA
DC-3	VAPOR RECOVERY CONN. (CGA LNG-300)	2 FPT x 3 CGA
DC-4	LIQUID SAMPLE QD AND PLUG	1/4
R-1	PB REGULATOR VALVE	2

Contact Information:

P.o.Box 198

Delphi, IN 46923

800-359-2556

sales@alloycustomproducts.com