



ALLOY CUSTOM PRODUCTS INC.

MODEL: ACP MS 15000 LIN





ALLOY CUSTOM PRODUCTS INC.



MODEL: ACP MS 15000

MAXIMIZED FOR LIN SERVICE

PRODUCT: LIN

WARM WATER CAPACITY: 15,109 US GALLONS

LIN @ 95% : 14,233 US GALLONS

MAWP: 38 PSIG

BAFFLES: NO BAFFLES REQUIRED FOR MOBILE STORAGE UNITS

MANWAY: WELDED (ENTRY)

OUTER VESSEL: A607-50 CARBON STEEL

INNER VESSEL: SA240-304 STAINLESS STEEL

SUSPENSION: AIR RIDE

DELIVERY SYSTEM: PRESSURE OFF

PIPING FEATURES:

BRONZE OR STAINLESS VALVES

EASY FLOW PIPING ARRANGEMENT





ALLOY CUSTOM PRODUCTS INC.

MODEL: ACP MS 15000

MAXIMIZED FOR LOX SERVICE

PRODUCT: LIN

WARM WATER CAPACITY: 15,109 US GALLONS

LIN @ 95% : 14,233 US GALLONS

MAWP: 38 PSIG

BAFFLES: NO BAFFLES REQUIRED FOR MOBILE STORAGE UNITS

MANWAY: WELDED (ENTRY)

OUTER VESSEL: A607-50 CARBON STEEL

INNER VESSEL: SA240-304 STAINLESS STEEL

SUSPENSION: AIR RIDE

PUMP DRIVE: ENGINE DRIVEN

PIPING FEATURES:

BRONZE VALVES

EASY PRIME PUMP LOCATION

EASY FLOW PIPING ARRANGEMENT

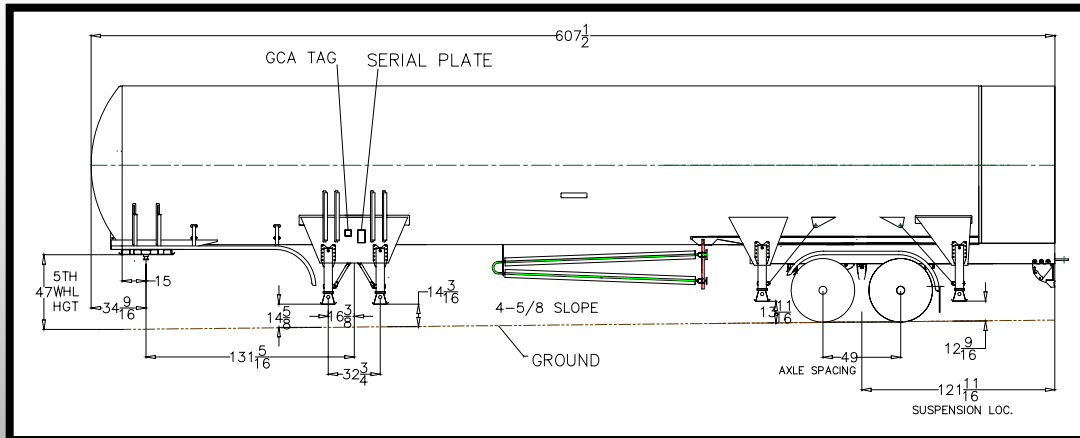

	STEERING AXLE		KINGPIN		TRACTOR TANDEM		TRAILER TANDEM		TOTAL WEIGHT	
	ENGLISH	METRIC	ENGLISH	METRIC	ENGLISH	METRIC	ENGLISH	METRIC	ENGLISH	METRIC
TRACTOR TARE	9,535	4,324.98	0	0	7,012	3,180.57	0	0	16,547	7,505.55
TRAILER TARE	797	361.51	9,519	4,317.72	8,722	3,956.21	17,746	8,049.40	27,265	12,367.13
PAYLOAD	0	0	0	0	0	0	0	0	0	0
FULL COMBINATION	10,332	4,686.49	9,519	4,317.72	15,734	7,136.78	17,746	8,049.40	43,812	19,872.68



ALLOY CUSTOM PRODUCTS INC.

MODEL: ACP MS 15000 FLOW SCHEMATIC

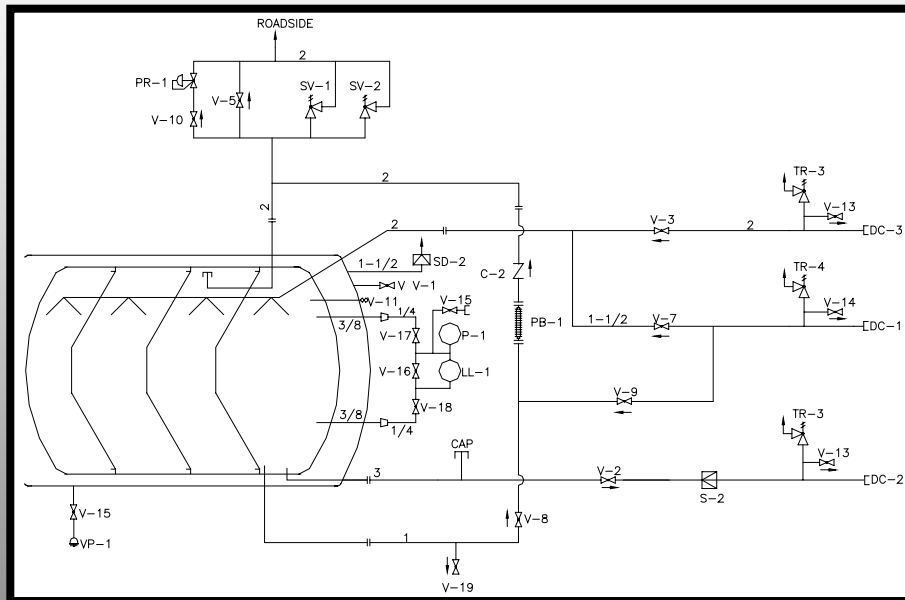

ITEM	DESCRIPTION	SIZE
C-2	PB COIL VAPOR-RETURN CHECK VALVE	2
DC-1	RECIRCULATION CONNECTION	2-1/2
DC-2	FILL-DRAIN-LINE CONNECTION	2-1/2
DC-3	TOP FILL CONNECTION	2-1/2
LL-1	LIQUID LEVEL GAUGE	-
PB-1	PRESSURE-BUILD COIL	-
PR-1	O.T.R. REGULATOR	1/2
P-1	INNER-VESSEL PRESSURE GAUGE	-
S-2	FILL-LINE STRAINER	2
SD-2	OUTER-JACKET PRESSURE RELIEF PLATE	5
SV-1	INNER-VESSEL SAFETY RELIEF VALVE 38 PSIG	2
SV-2	INNER-VESSEL SAFETY RELIEF VALVE 57 PSIG	2
TR-3	FILL LINE THERMAL RELIEF VALVE 200 PSIG	1/2
TR-4	RECIRCULATION-LINE THERMAL RELIEF VALVE 450 PSIG	1/2
V-2	BOTTOM FILL VALVE	3
V-3	TOP FILL VALVE	2
V-5	MANUAL VENT VALVE	2
V-7	PUMP RECIRCULATION VALVE	1-1/2
V-8	PB INLET	1
V-9	PB COIL FORCE FEED	1/2
V-10	O.T.R. ISOLATION	1/2
V-11	95% TRYCOCK	3/8
V-13	FILL LINE BLEED	3/8
V-14	RECIRCULATION LINE BLEED	3/8
V-15	THERMOCOUPLE ISOLATION VALVE	1/8
V-16	LL GAUGE EQUALIZATION VALVE	1/8
V-17	L.P. ISOLATION	1/4
V-18	H.P. ISOLATION	1/4
V-19	EMPTY TRYCOCK	3/8
VP-1	THERMOCOUPLE PROBE	1/8
VV-1	EVACUATION VALVE	1-1/2

Contact Information:

P.o.Box 198

Delphi, IN 46923

800-359-2556

sales@alloycustomproducts.com