



ALLOY CUSTOM PRODUCTS INC.

MODEL: ACP T-85 LIN (ALUMINUM)





ALLOY CUSTOM PRODUCTS INC.

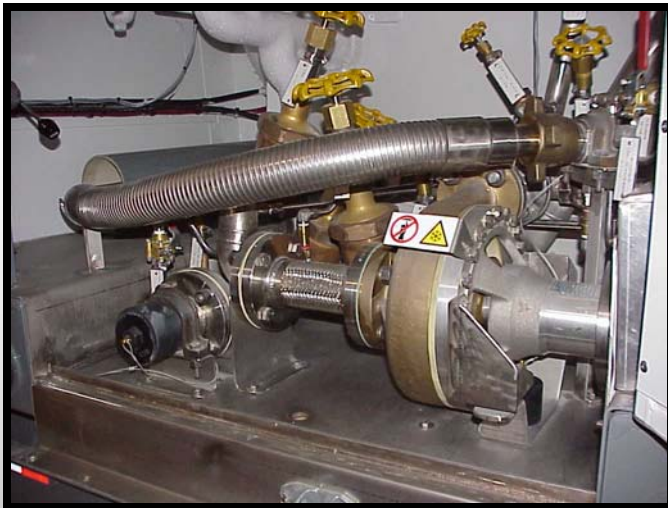

MODEL: ACP T-85

ALUMINUM UNIT MAXIMIZED FOR LIN SERVICE

SPECIFICATIONS:

PRODUCT: LIN

WARM WATER CAPACITY: 8,447 US GALLONS

LIN @ 95% : 7,928 US GALLONS

MAWP: 40 PSIG

BAFFLES: 3 TRANSVERSE BAFFLES

MANWAY: WELDED (ENTRY)

OUTER VESSEL: 5083 ALUMINUM

INNER VESSEL: 5083 ALUMINUM

SUSPENSION: AIR RIDE

PUMP DRIVE: CUSTOMER SPECIFIED

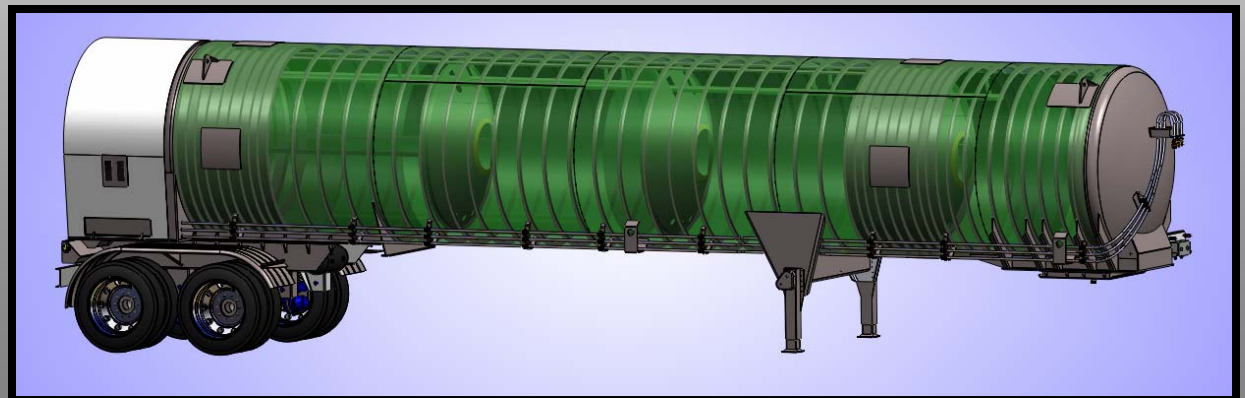



ALLOY CUSTOM PRODUCTS INC.

MODEL: ACP T-85

ALUMINUM UNIT MAXIMIZED FOR LIN SERVICE

SPECIFICATIONS:

PRODUCT: LIN

WARM WATER CAPACITY: 8,447 US GALLONS

LIN @ 95% : 7,928 US GALLONS

MAWP: 40 PSIG

BAFFLES: 3 TRASVERSE BAFFLES

MANWAY: WELDED (ENTRY)

OUTER VESSEL: 5083 ALUMINUM

INNER VESSEL: 5083 ALUMINUM

SUSPENSION: AIR RIDE

PUMP DRIVE: CUSTOMER SPECIFIED

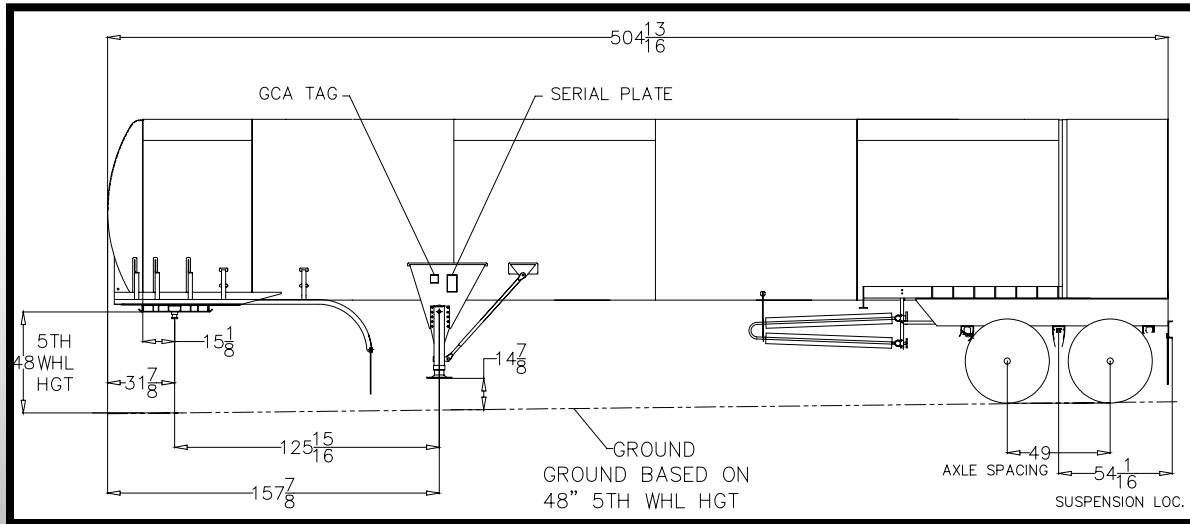

	STEERING AXLE		KINGPIN		TRACTOR TANDEM		TRAILER TANDEM		TOTAL WEIGHT	
	ENGLISH	METRIC	ENGLISH	METRIC	ENGLISH	METRIC	ENGLISH	METRIC	ENGLISH	METRIC
TRACTOR TARE	8,620	3,909.94	0	0	7,260	3,293.06	0	0	15,880	7,2203.00
TRAILER TARE	513	232.69	4,573	2,074.26	4,060	1,841.57	9,840	4,463.32	14,413	6,537.59
PAYLOAD	2,867	1,300.44	25,548	11,588.31	22,681	10,287.87	24,159	10,958.28	49,707	22,546.59
FULL COMBINATION	12,000	5,443.08	30,121	13,662.58	34,001	15,422.51	33,999	15,421.60	80,000	36,287.20



ALLOY CUSTOM PRODUCTS INC.

MODEL: ACP T-85 FLOW SCHEMATIC

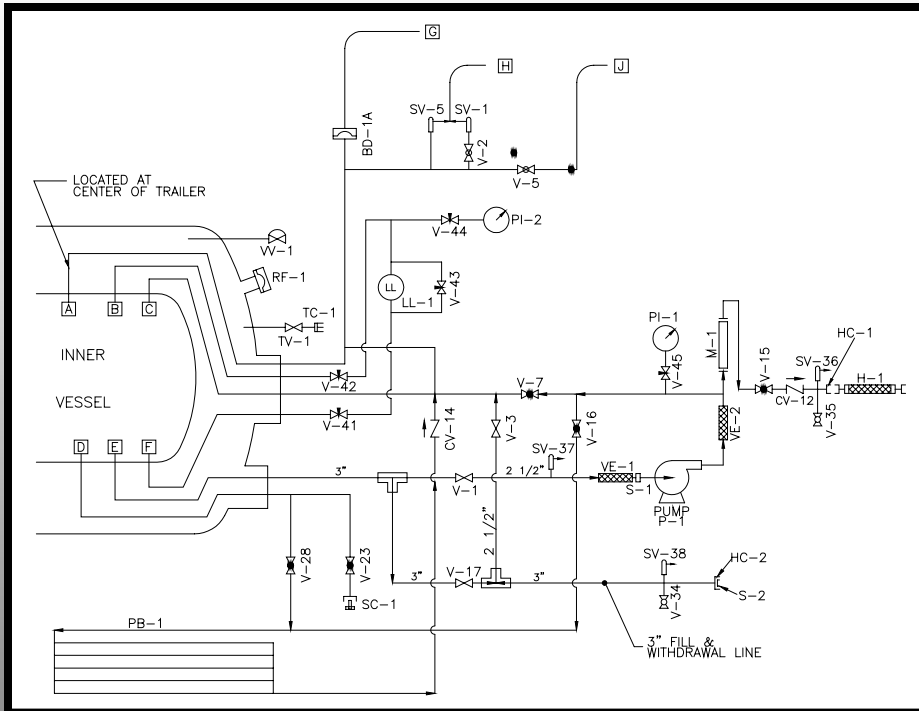

ITEM	DESCRIPTION	SIZE	MANUFACTURER
V1	PUMP INLET VALVE, GATE	2 1/2"	GODDARD #B3 10X20T
V2	OVER THE ROAD ISOLATION VALVE, GLOBE	1/2"	GODDARD #R22X4T
V3	TOP FILL VALVE, GATE	2 1/2"	GODDARD #B3 10X20T
V4	VENT VALVE, GLOBE	2"	GODDARD #R22-16T
V7	REGULATOR VALVE, GLOBE	1 1/2"	GODDARD #R2218S12T4
V15	PUMP DISCHARGE VALVE, GLOBE	1 1/2"	GODDARD #R2218S12T4
V16	FORCE FEED VALVE, GLOBE	1/2"	GODDARD #R22X4T4
V17	FILL VALVE, GATE	3"	GODDARD #B3 10X24T
V23	LIQUID SAMPLE VALVE, GLOBE	1/2"	GODDARD #R22X4T
V28	PRESSURE BUILD FEED VALVE, GLOBE	1 1/2"	GODDARD #R2218S12T4
V34	FILL HOSE BLEED VALVE, BALL	1/2"	WORCESTER #W411TSE
V35	PUMP DISCHARGE BLEED VALVE, BALL	1/2"	WORCESTER #W411TSE
V41	HIGH PRESSURE ISOLATION VALVE, NEEDLE	1/8"	HOKE D07 12-M2B-HPS-18
V42	LOW PRESSURE ISOLATION VALVE, NEEDLE	1/8"	HOKE D07 12-M2B-HPS-18
V43	LL GAGE EQUAL VALVE, NEEDLE	1/8"	HOKE D07 12-M2B-HPS-18
V44	PRESSURE GAGE ISOLATION VALVE, NEEDLE	1/8"	HOKE D07 12-M2B-HPS-18
V45	PUMP PRESSURE GAGE ISOLATION VALVE, NEEDLE	1/8"	HOKE D07 12-M2B-HPS-18
CV12	PUMP DISCHARGE SWING CHECK	1 1/2"	GODDARD #S88A-12BWS10
CV14	PRESSURE BUILD COIL GAS PHASE SWING CHECK	2"	GODDARD #S88A-18BWS10
V31	MINI VACUUM VALVE, DIAPHRAGM	1 1/2"	HILLIS MCANARRA D62-N1
TV1	THERMOCOUPLE ISOLATION VALVE, BELLOW SEAL	1/8"	HOKE #K51 F2B-HPS-18
TC-1	THERMOCOUPLE	--	FREDRICKS #2100-10-2A
RF-1	OUTER VESSEL SAFETY HEAD, O-RING, SEE NOTE 6	6"	--
SV1	ROAD RELIEF REGULATOR VALVE, SET @ 17 PSIG	1/2"	IMCASH #RFR42
SV3	MAIN TANK SAFETY, SET @ 40 PSIG, SEE NOTE 5	1 1/2" X 2"	RICKS WOODS SHERRIDMAN #RWS10
SV36	PUMP DISCHARGE SAFETY, SET @ 40 PSIG	1/2"	GENERANT CRV-M 500B-FS-40 PSI
SV37	PUMP SUCTION SAFETY, SET @ 50 PSIG	1/2"	GENERANT CRV-M 500B-FS-40 PSI
SV38	FILL LINE SAFETY, SET @ 100 PSIG	1/2"	GENERANT CRV-M 500B-FS-150 PSI
BD-1A	RUPTURE DISC, SET @ 55 PSIG, SEE NOTE 7	2"	FIKE QUICK SET S5 W/NICKLE DISC
VE1	VIBRATION ELIMINATOR	2 1/2"	FLEXIBLE COMPONENTS
VE2	VIBRATION ELIMINATOR	1 1/2"	FLEXIBLE COMPONENTS
S-1	PUMP INLET STRAINER	2 1/2"	40 MESH MONEL
S-2	FILL LINE SCREEN	2 1/2"	40 MESH MONEL
H-1	HOSE, 18 FT LONG w/IMBLED COUPLER CONNECTIONS	2"	FLEXIBLE COMPONENTS #52M52 105006 DS40G S HP NHEA
HC-1	PUMP DISCHARGE HOSE CONNECTION, SS	1 1/2"	ADME #N 200-400-106-15
HC-2	FILL HOSE CONNECTION, SS	P 1/2 1/2" GA	ADME #N 200-400-106-25
SG1	SAMPLE CONNECTION, NITROGEN	--	SWABELOK #SS-004-B1-400-45 & PLUG #SS-004-BP-K5
M1	METER	2"	SPONSLER #640TN
PI-1	VESSEL PRESSURE GAGE, 0-100 PSIG	4 1/2" DIAL	WEBER
PI-2	PUMP DISCHARGE PRESSURE GAGE, 0-400 PSIG	4 1/2" DIAL	WEBER
LL-1	LIQUID LEVEL GAGE, 0-80 IN	6" DIAL	BARTON #227
P-1	PUMP, CENTRIFUGAL		
PB-1	PRESSURE BUILDING COIL		

Contact Information:

P.o.Box 198

Delphi, IN 46923

800-359-2556

sales@alloycustomproducts.com