



ALLOY CUSTOM PRODUCTS INC.

MODEL: ACP T-77 LIN (ALUMINUM)





ALLOY CUSTOM PRODUCTS INC.



MODEL: ACP T-77

ALUMINUM UNIT MAXIMIZED FOR LIN SERVICE

SPECIFICATIONS:

PRODUCT: LIN

WARM WATER CAPACITY: 7,700 US GALLONS

LIN @ 95% : 7,192 US GALLONS

MAWP: 40 PSIG

BAFFLES: 3 TRANSVERSE BAFFLES

MANWAY: WELDED (ENTRY)

OUTER VESSEL: 5083 ALUMINUM

INNER VESSEL: 5083 ALUMINUM

SUSPENSION: AIR RIDE

PUMP DRIVE: CUSTOMER SPECIFIED





ALLOY CUSTOM PRODUCTS INC.

GENERAL ARRANGEMENT AND SAMPLE WEIGHT DISTRIBUTION

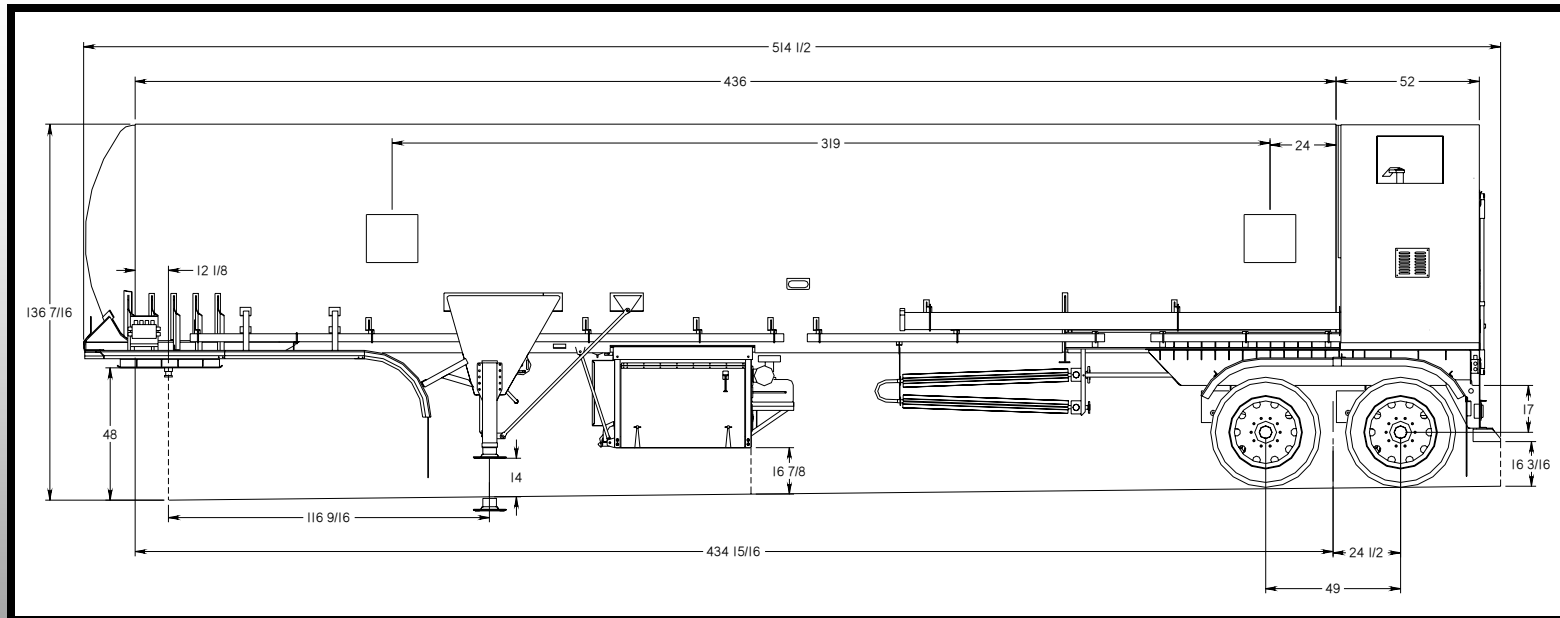

WEIGHT DISTRIBUTION	FRONT TRACTOR (LB)	REAR TRACTOR (LB)	REAR TRAILER (LB)	TOTAL (LB)	KINGPIN (LB)
TRACTOR TARE	9000	6800	0	15800	0
TRAILER TARE	516	4676	10088	15280	5192
PAYLOAD	2484	22524	23912	48920	25008
TOTAL	12000	34000	34000	80000	30200



ALLOY CUSTOM PRODUCTS INC.

ACP T-77 SAMPLE FLOW SCHEMATIC

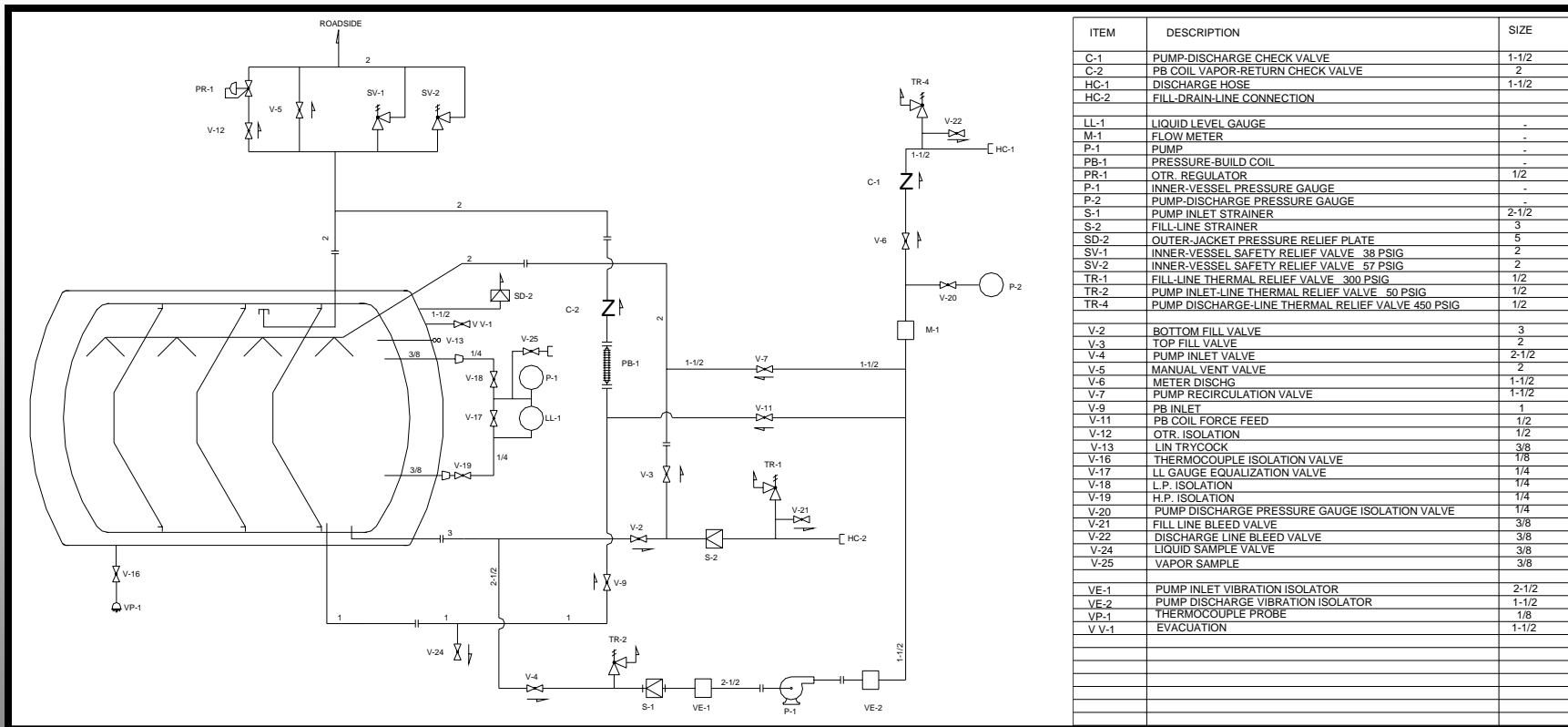

Contact Information:

P.o.Box 198

Delphi, IN 46923

800-359-2556